

NO AUTO POWER OFF DIGITAL INDICATOR

DATA
OUTPUT

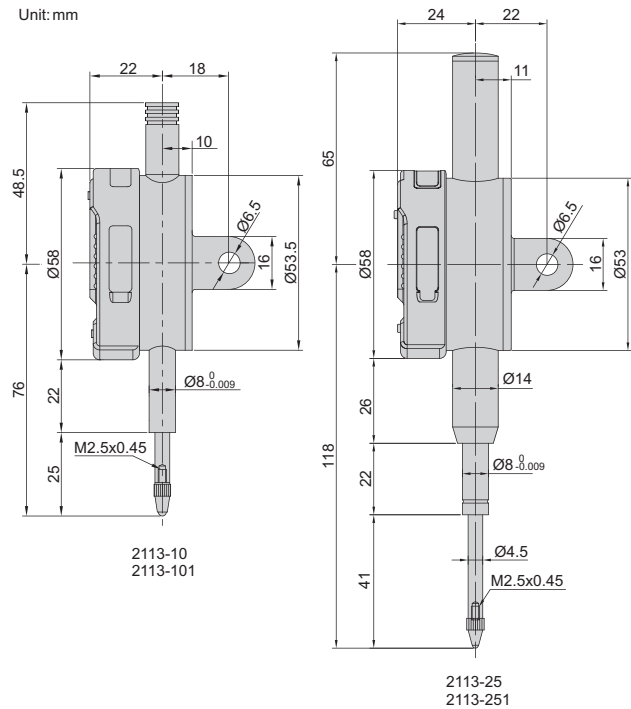

Unit: mm



- No auto power off, tracking the deformation of mould and steel structure for a long time
- Low power consumption
- Button function: on/off, zero, inch/mm
- CR2032 battery
- Data output
- Optional accessory: data output system (code 7305-SPC1)
- Optional accessory: backs, contact points

data output system (optional)



Resolution 0.001mm/0.00005"

Code	Range	Accuracy	Hysteresis	Remark
2113-101*	12.7mm/0.5"	5µm	2µm	lug back
2113-251*	25.4mm/1"	5µm	3µm	lug back
2113-101F*	12.7mm/0.5"	5µm	2µm	flat back
2113-251F*	25.4mm/1"	5µm	3µm	flat back

Resolution 0.01mm/0.0005"

Code	Range	Accuracy	Hysteresis	Remark
2113-10*	12.7mm/0.5"	20µm	10µm	lug back
2113-25*	25.4mm/1"	20µm	10µm	lug back
2113-10F*	12.7mm/0.5"	20µm	10µm	flat back
2113-25F*	25.4mm/1"	20µm	10µm	flat back

*Supplied with manufacturer calibration certificate



www.insize.com