

# BENCH CENTER

HIGH  
PRECISION



4788-300

Unit: mm

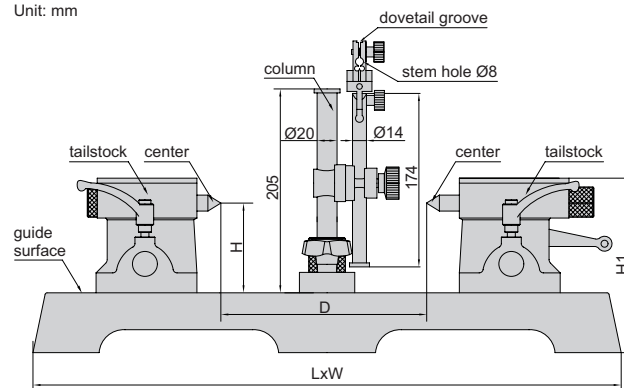

- Hardened cast-iron guide surface
- Movable column

(mm)

Code	Accuracy*	Center height (H)	Distance between two centers(D)	Length (L)	Width (W)	Height (H1)	Taper of center	Weight
4788-300	0.01mm	90	300	590	192	175	MT1	34kg
4788-400	0.01mm	130	400	770	206	241	MT2	66kg
4788-600	0.01mm	130	600	930	220	250	MT2	90kg
4788-600H2	0.01mm	200	600	930	220	325	MT2	105kg
4788-1000	0.01mm	130	1000	1330	220	262	MT2	112kg
4788-1000H2	0.01mm	200	1000	1330	220	337	MT2	125kg
4788-1000H3	0.01mm	300	1000	1330	220	442	MT2	165kg

\*The accuracy is the parallelism of the line between two centers to the guide surface