

THREAD GAUGE

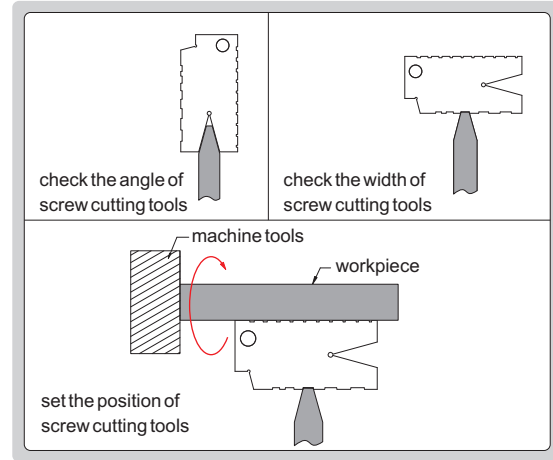

4812-E

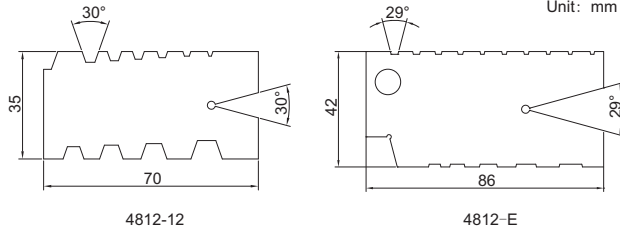

- To check and set screw cutting tools
- Angle accuracy: $\pm 10\text{min}$.

Code	Range	Thread type	Pitch
4812-12	2- 12mm	TR 30°	2, 3, 4, 5, 6, 7, 8, 9, 10, 12mm
4812-E	1- 10TPI	ACME 29°	1, 1-1/3, 1-1/2, 1-3/4, 2, 2-1/2, 3, 4, 5, 6, 7, 8, 9, 10TPI