

WELDING GAUGE

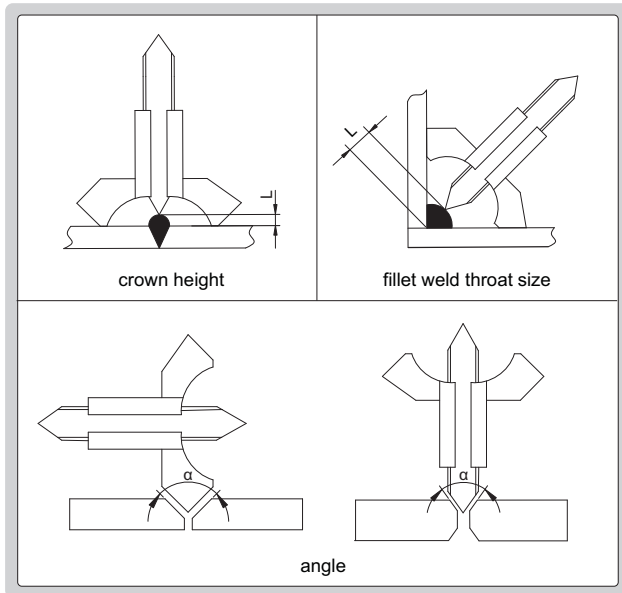

4830

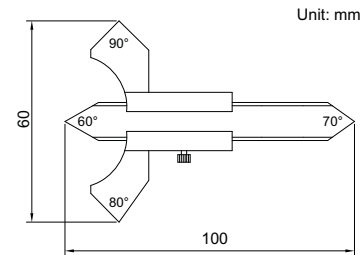

Code	Measurement	Range	Graduation	Accuracy
4830	crown height	0 - 8mm	0.1mm	±0.1mm
	fillet weld throat size	0 - 20mm	0.1mm	±0.3mm
	angle	60°, 70°, 80°, 90°	—	±1°

- Made of stainless steel
- Stain chrome plated reading surface