

WELDING GAUGE

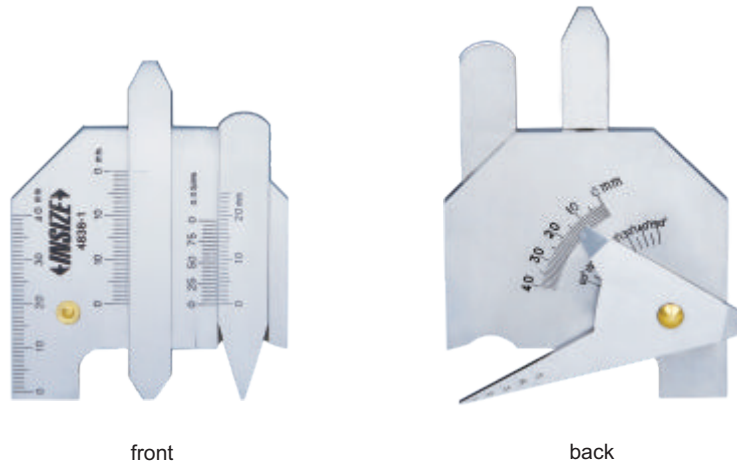

4838-1

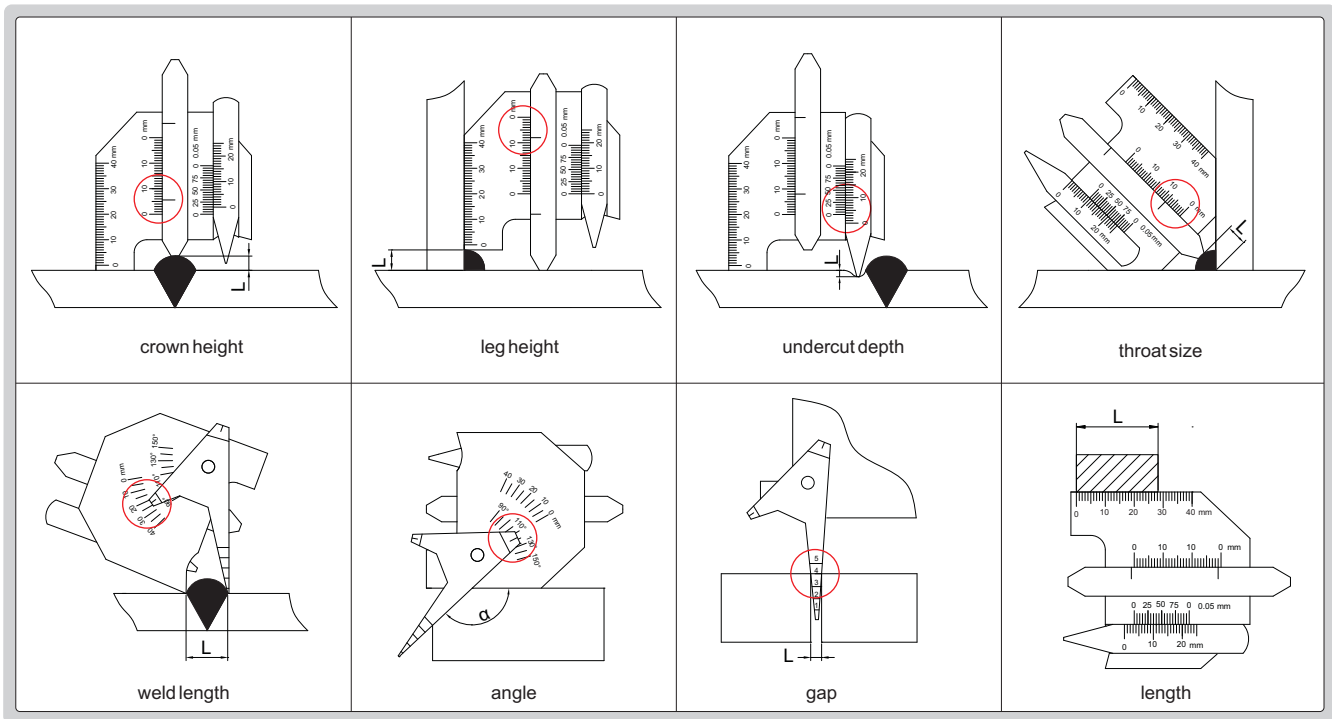

■ Made of stainless steel

Code	Measurement	Range	Graduation	Accuracy
4838-1	crown height	0 - 10mm	1mm	±0.5mm
	leg height	0 - 14mm	1mm	±0.5mm
	undercut depth	0 - 5mm	0.05mm	±0.05mm
	throat size	0 - 13mm	1mm	±0.5mm
	weld length	0 - 40mm	1mm	±1mm
	angle	90° - 150°	5°	±1°
	gap	0.5 - 5mm	1mm	±0.5mm
	length	0 - 40mm	1mm	±0.5mm

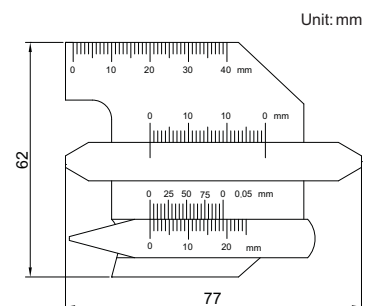

Unit: mm