

# THICKNESS GAUGE

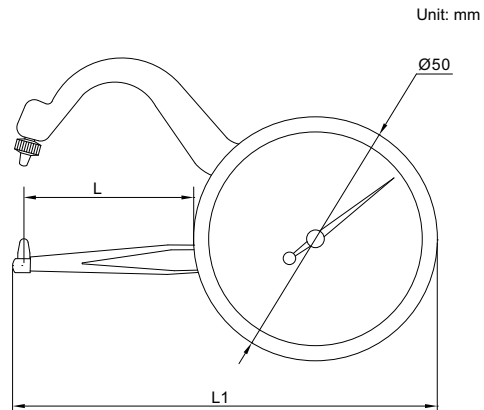

2862-101



(mm)

Code	Range	Graduation	Accuracy	L	L1
2862-101	0-10mm	0.05mm	±0.1mm	35	85
2862-102	0-10mm	0.05mm	±0.1mm	60	110