

# SAW SETTING DIAL GAUGE



front



back

**2869-2**

- For saw setting and step measurement
- Dial on both sides
- With limit hand

Code	Range	Graduation	Accuracy
2869-2	0-2mm	0.02mm	±0.02mm

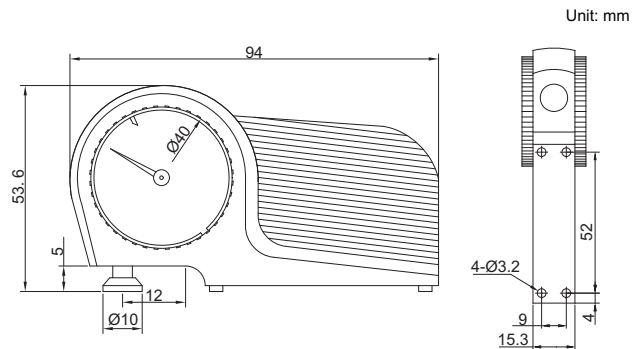

saw setting

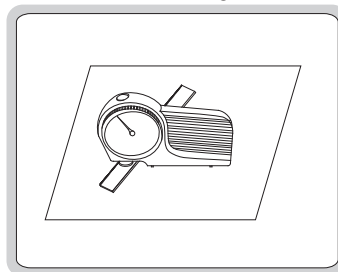

step measurement

