

CONTACT POINT

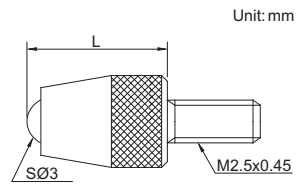

- For dial indicators and digital indicators

BALL POINT



Code	Material of measuring face	L(mm)
6282-0101	carbide	7.3
6282-0103	ceramic	7.3
6282-0104	carbide	8.3
6282-0106	carbide	12.1
6282-0107	carbide	14
6282-0108	carbide	15
6282-0109	ceramic	15
6282-0110	carbide	17
6282-0111	carbide	19.3
6282-0112	carbide	20
6282-0113	ceramic	20
6282-0114	carbide	22
6282-0115	carbide	25
6282-0116	ceramic	25
6282-0117	carbide	30
6282-0118	ceramic	30

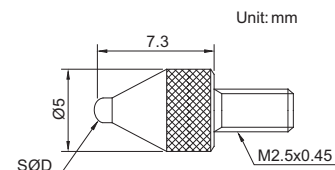

Code	Material of measuring face	SØD(mm)
6282-0301	steel	1
6282-0302	carbide	1.5
6282-0303	carbide	1.8
6282-0304	carbide	2.5
6282-0305	carbide	4

SHELL TYPE POINT

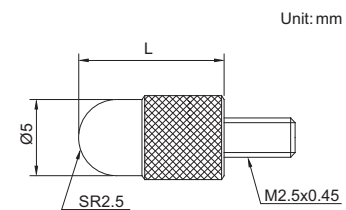

Code	Material of measuring face	L(mm)
6282-0202	steel	5
6282-0203	steel	10
6282-0205	steel	15
6282-0207	steel	20
6282-0208	steel	25
6282-0210	steel	30

SPHERICAL POINT

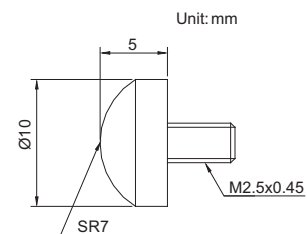

Code	Material of measuring face
6282-0401	steel

CONICAL POINT

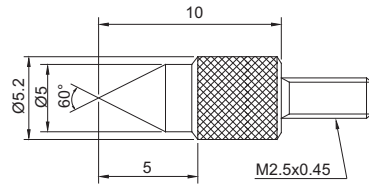
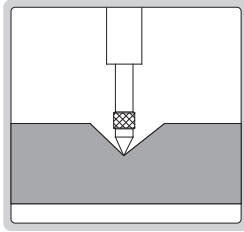

6282-0601

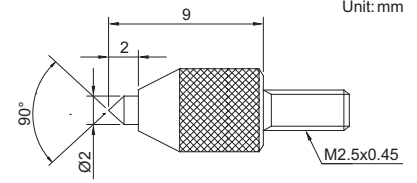

6282-0801

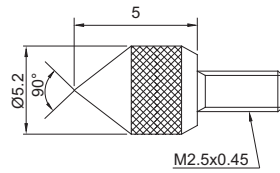

6282-0701

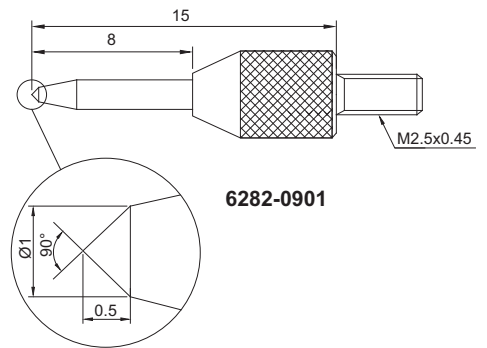

6282-0901

Unit: mm

Code	Material of measuring face
6282-0601	steel
6282-0701	steel
6282-0801	steel
6282-0901	steel

FLAT POINT

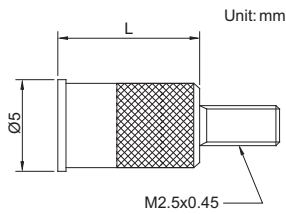

M2.5x0.45

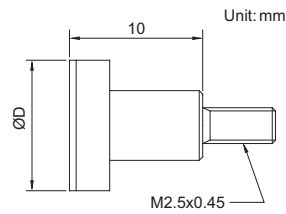

M2.5x0.45

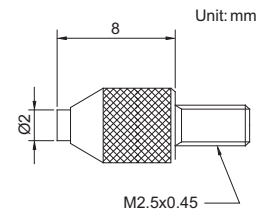

M2.5x0.45

Code	Material of measuring face	L(mm)
6282-1101	steel	8
6282-1102	steel	10

Code	Material of measuring face	ØD(mm)
6282-1201	steel	10
6282-1202	steel	15
6282-1203	steel	20
6282-1204	steel	25
6282-1205	steel	30

Code	Material of measuring face
6282-1301	carbide

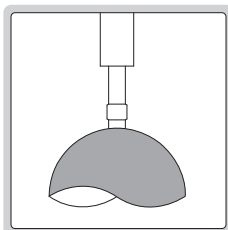

NEEDLE POINT

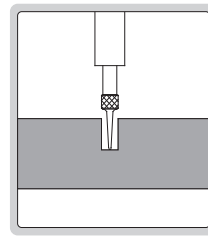
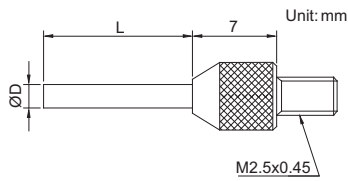

(mm)

Code	Material of measuring face	ØD	L
6282-1701	steel	0.45	3
6282-1702	steel	0.45	5
6282-1703	carbide	1	3
6282-1704	carbide	1	5
6282-1705	carbide	1	8
6282-1706	carbide	1	10
6282-1707	carbide	1	20
6282-1708	carbide	1	40
6282-1709	carbide	1.5	5
6282-1710	carbide	1.5	10
6282-1711	carbide	1.5	13
6282-1712	carbide	1.5	20
6282-1713	carbide	1.5	40
6282-1714	carbide	2	8
6282-1715	carbide	2	18
6282-1716	carbide	2	28
6282-1717	carbide	2	40

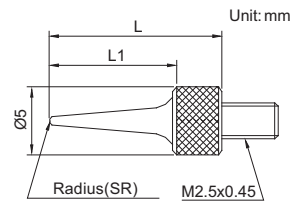

(mm)

Code	Material of measuring face	L1	L	SR
6282-1601	steel	11	15	0.4
6282-1602	steel	13	17	0.2
6282-1603	steel	21	25	0.4
6282-1604	steel	31	35	0.4

KNIFE EDGE POINT

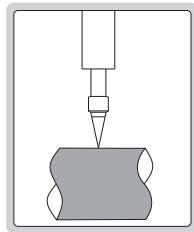
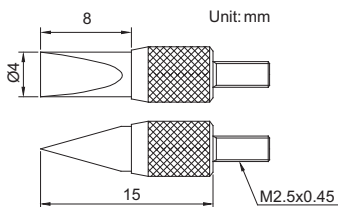

Code	Material of measuring face
6282-1001	steel

BLADE POINT

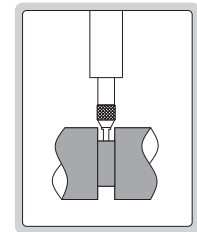
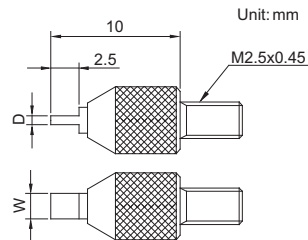

(mm)

Code	Material of measuring face	D	W
6282-1801	steel	0.4	2
6282-1802	steel	0.6	2
6282-1803	steel	1	4

ROLLER POINT

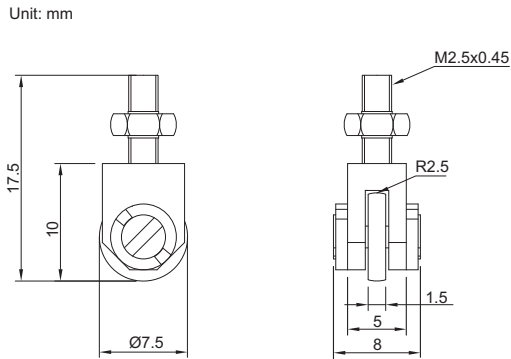

Code	Material of measuring face
6282-1901	steel

EXTENSION ROD

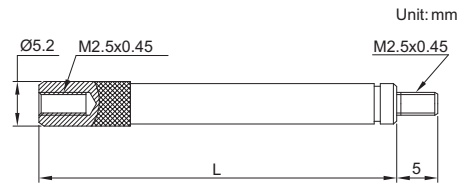

(mm)			(mm)		
Code	Material of measuring face	L	Code	Material of measuring face	L
6282-2001	steel	10	6282-2010	steel	55
6282-2002	steel	15	6282-2011	steel	60
6282-2003	steel	20	6282-2012	steel	65
6282-2004	steel	25	6282-2013	steel	70
6282-2005	steel	30	6282-2014	steel	75
6282-2006	steel	35	6282-2015	steel	80
6282-2007	steel	40	6282-2016	steel	90
6282-2008	steel	45	6282-2017	steel	100
6282-2009	steel	50			

POINT SET

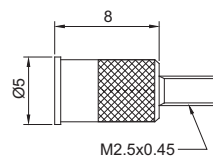

Flat Point

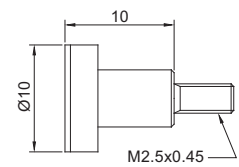

Flat Point

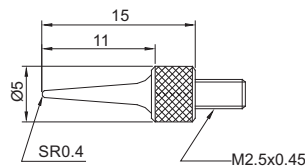

Needle Point

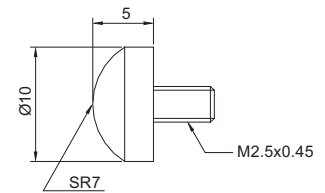

Spherical Point

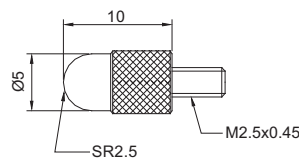

Shell Type Point

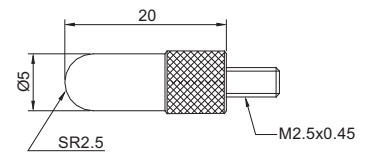

Shell Type Point

Code	Material of measuring face
6282-S6	steel