

BORE GAUGE

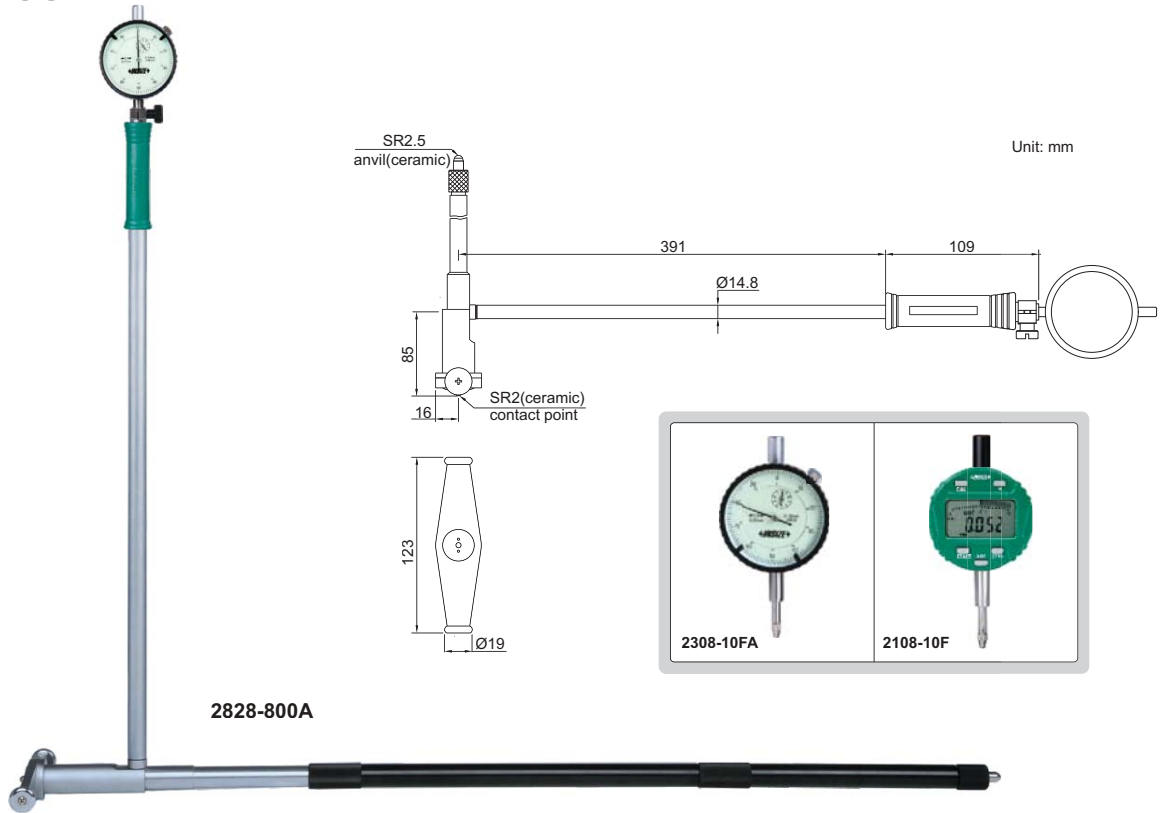

Code	Range	Indicator	Accuracy	Repeatability
2828-800A	400-800mm	dial indicator code 2308-10FA range 10mm, graduation 0.01mm	±0.025mm	0.003mm
2128-800A	400-800mm	digital indicator code 2108-10F range 12.7mm/0.5", resolution 0.002mm/0.0001"	±0.025mm	0.003mm