

# CAN SEAM MICROMETER



3293-131



3293-132



3293-133

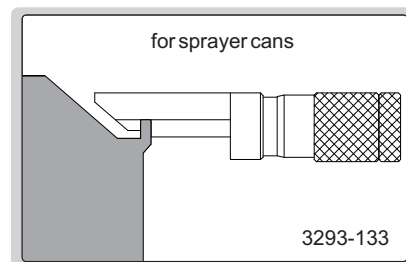
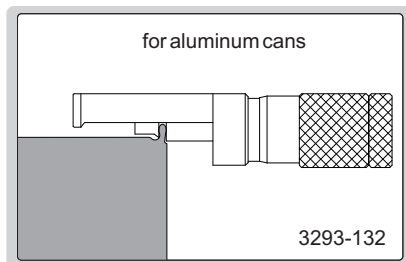
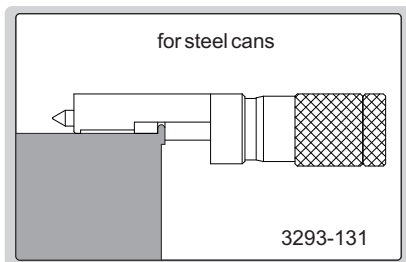
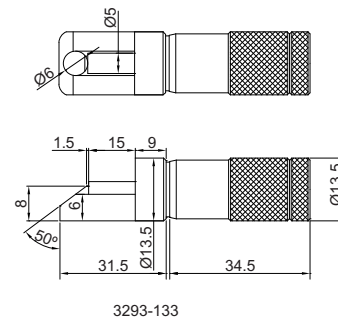
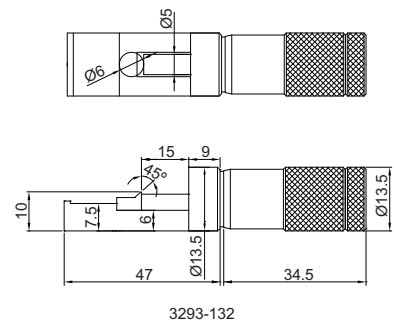
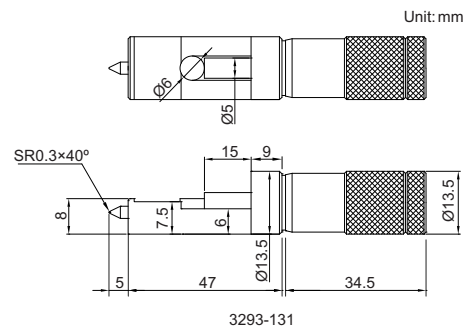

| Code     | Range  | Accuracy |
|----------|--------|----------|
| 3293-131 | 0-13mm | 4µm      |
| 3293-132 | 0-13mm | 4µm      |
| 3293-133 | 0-13mm | 4µm      |

- Measure the width, height and depth of can seams
- Graduation 0.01mm