

DIGITAL SPLINE MICROMETER

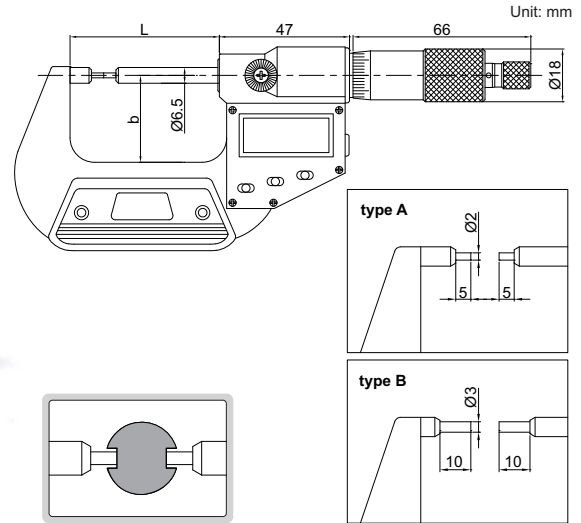

3533-25BA



Unit: mm

(mm)

Code	Range	Type	Accuracy	L	b
3533-25A	0-25mm/0-1"	A	±4μm	57	32
3533-50A	25-50mm/1-2"	A	±4μm	82	44.5
3533-75A	50-75mm/2-3"	A	±5μm	107	57
3533-100A	75-100mm/3-4"	A	±5μm	132.6	69.5
3533-25BA	0-25mm/0-1"	B	±4μm	57	32
3533-50BA	25-50mm/1-2"	B	±4μm	82	44.5
3533-75BA	50-75mm/2-3"	B	±5μm	107	57
3533-100BA	75-100mm/3-4"	B	±5μm	132.6	69.5

- Measure splined shafts, slots and keyways
- Resolution 0.001mm/0.00005"
- IP54 dust/waterproof
- Button function: on/off, set, mm/inch, ABS/INC, data output
- RS232 data output
- SR44 or LR44 battery, automatic power off
- Ratchet stop
- Carbide measuring faces
- Supplied with setting standards(except 0-25mm/0-1")
- Optional accessory: SPC cable (page A1-A2)