

DIGITAL INTERCHANGEABLE ANVIL MICROMETER

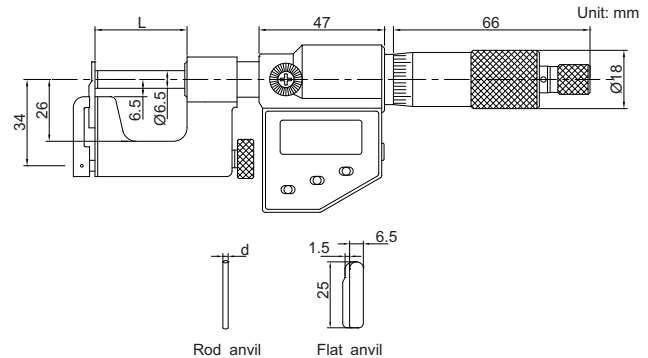

3562-25A

- Measure tube thickness, shoulder edge distance, rivet head height, etc.
- Supplied with flat anvil and rod anvil
- Resolution 0.001mm/0.00005"
- IP54 dust/waterproof
- Button function: on/off, set, mm/inch, ABS/INC, data output
- RS232 data output
- SR44 or LR44 battery, automatic power off
- Ratchet stop
- Carbide spindle tip
- Setting standards are included(except 0-25mm/0-1")
- Optional accessory: SPC cable (page A1-A2)



Code	Range	Accuracy	L	d
3562-25A	0-25mm/0-1"	±4μm	28.5	Ø3
3562-50A	25-50mm/1-2"	±4μm	53.5	Ø5

