

ELECTRONIC ZERO SETTER

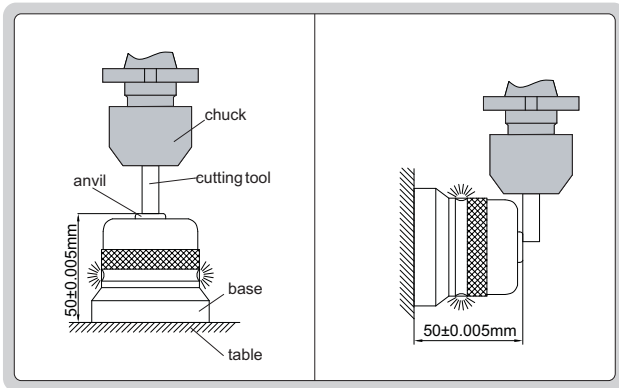

6550-50A

- The base is electrically conducted to the cutting tools through the table and chuck, the LED lights up when the cutting tool touches the anvil
- Magnetic base
- Battery LR44 or SR44

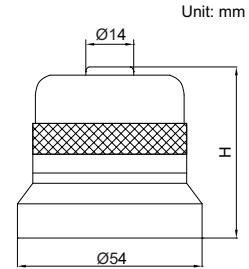

Code	Height (H)	Accuracy
6550-50A	50mm	±5µm